

QUADTEK M721

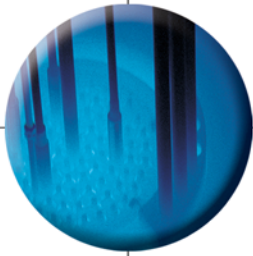

Remote Auto Iris Controller

Features

- Video image contrast adjustment
- Locate next to monitor in the control room
- Simple connection, shares same coax as camera



Normal operation of an industrial process such as a utility boiler or kiln includes a wide variation of operating loads from cold start-up to full load. Even the most versatile of auto-iris cameras cannot compensate for these changing light levels. The Quadtek **M721** auto-iris controller allows the operator to make level adjustments to the M508 camera auto-iris from the control room. Level control of the auto-iris means that flame details will not be lost due to camera saturation. During start-up, burner viewing will not be lost due to insufficient levels of brightness.

Connection is made simple because the M721 controls the camera's iris while sharing the same coax that is normally run from the camera to the control room.

QUADTEK M721

Specifications and Performance

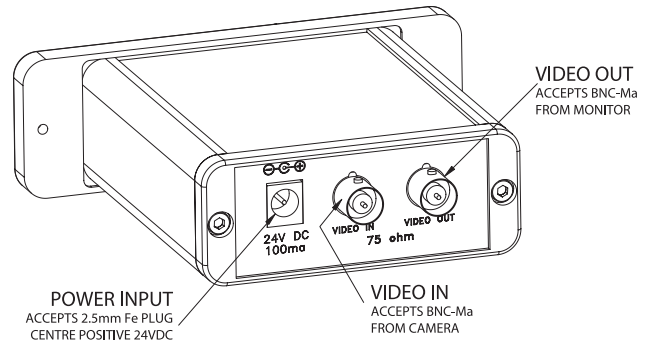
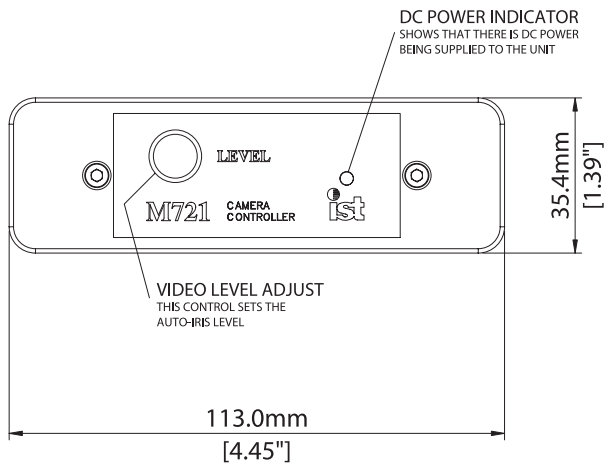

Power Requirements	30Vdc; 500mA via 100-240 Vac power adaptor
Physical Dimensions	1.28" H x 3.50" W x 4.25" D (33mm x 89mm x 108mm)
Installation Clearances	3.0" in rear (76mm)
Operating Temperature Range	32 to 121° F (0 to 50° C)
Storage Temperature Range	-13 to 158° F (-25 to 70° C)
Relative Humidity	0 to 95%
Camera Requirements	Quadtek M508 Lynx camera with remote iris control option
Video Input	1 channel 75 ohm composite video with BNC connector
Video Output	1 channel 75 ohm composite video with BNC connector

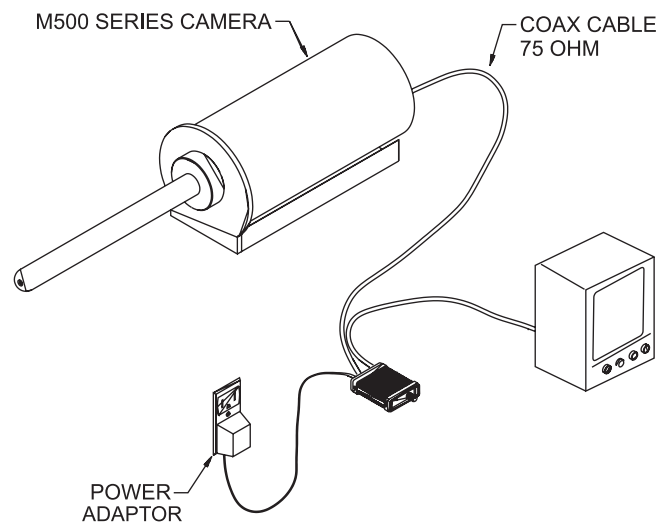

Imaging and Sensing Technology Corporation

204 IST Center
Horseheads, NY 14845 USA
Tel: 607-562-4300
800-432-1478
Fax: 607-562-4392
E-mail: istrees@istcorp.com

19501 144th Avenue NE, Suite F1100
Woodinville, WA 98072 USA
Tel: 425-881-0778
Fax: 425-869-0667
E-mail: sales@quadtek.com

12954 Stonecreek Drive, Suite C
Pickerington, OH 43147 USA
Tel: 614-367-2050
Fax: 614-367-2464
E-mail: sales@quadtek.com

Station Road
Alton, Hampshire
GU34 2PZ, UK
Tel: 01420 541600
Fax: 01420 541700
E-mail: info@istcorp.co.uk